

Manufacturer's Data and Design Characteristics

Characteristics		HELI				
1.01	Manufacturer's Name					
1.02	Model Designation	CPD15	CPD16	CPD18	CPD20	
1.03	Configuration Number	SQ-GB2Li	SQ-GB2Li	SQ-GB2Li	SQ-GB2Li	
1.04	Load Capacity	Q (kg)	1500	1600	1800	2000
1.05	Load Center	c (mm)	500	500	500	500
1.06	Power Type		Battery	Battery	Battery	Battery
1.07	Operator Type		Seated	Seated	Seated	Seated
1.08	Wheelbase	L1 (mm)	1292	1292	1400	1400
Wheels & Tyres						
2.01	Tyre Type		SE	SE	SE	SE
2.02	Tyres Number (Front/Rear)		2/2	2/2	2/2	2/2
2.03	Tread(centre of tyre),front	W3 (mm)	910	910	920	920
2.04	Tread(centre of tyre),rear	W2 (mm)	180	180	180	180
2.05	Tyre Size, Front		18 × 7-8	18 × 7-8	200/50-10	200/50-10
2.06	Tyre Size, Rear		140/55-9	140/55-9	140/55-9	140/55-9
Dimensions						
3.01	Load Distance	L2 (mm)	365	365	365	372
3.02	Mast Tilt Angle,F/R	a/β (°)	5/7	5/7	5/7	5/7
3.03	Height with Mast Lowered	H1 (mm)	2175	2175	2175	2175
3.04	Free Lift	H3 (mm)	90	90	90	90
3.05	Standard Lift Height	H (mm)	3300	3300	3300	3300
3.06	Height with Mast Extended	H2 (mm)	4039	4039	4039	4039
3.07	Overhead Guard Height	H4 (mm)	2040	2040	2040	2040
3.08	Fork Size T × W × L	L4/W/T(mm)	35 × 100 × 920	35 × 100 × 920	35 × 100 × 920	40 × 122 × 920
3.09	Fork Carriage to DIN 15173 A/B		2A	2A	2A	2A
3.10	Length to fork face	l' (mm)	1852	1852	1962	1967
3.11	Overall Width	W1 (mm)	1060	1060	1120	1120
3.12	Outside Turning Radius	r (mm)	1487	1487	1595	1595
3.13	Ground Clearance at mast ,Loaded	H5 (mm)	85	85	90	90
3.14	Ground Clearance at centre of wheelbase ,Loaded	H6 (mm)	100	100	100	100
3.15	Right Stack Aisle width (Pallet size 1000x1000mm, clearance:200mm)	Ast (mm)	3140	3140	3248	3248
3.16	Right Stack Aisle width (Pallet size 1200x1200mm, clearance:200mm)	Ast (mm)	3363	3363	3471	3471
3.17	Lateral Fork Adjustment (Outside of Forks) Max./Min.	W5 (mm)	960/200	960/200	1030/200	1030/245
Performances						
4.01	Travel Speed,loaded/unloaded	km/h	16/16	16/16	16/16	16/16
4.02	Lifting Speed,loaded/unloaded	m/s	0.38/0.6	0.43/0.6	0.43/0.6	0.40/0.60
4.03	Lowering Speed,loaded/unloaded	m/s	0.50/0.40	0.50/0.40	0.50/0.40	0.50/0.40
4.04	Gradient performance with loaded	%	20	20	20	20
4.05	Max. draw bar pull with load	N	13500	13500	14500	14500
Weight						
5.01	Total Approximate Weight(W/O battery)	kg	2990	3250	3350	3600
5.02	Axle Loading*: Unloaded,Front/Rear	kg	1420/1570	1490/1760	1620/1730	1640/1960
5.03	Axle Loading*: Loaded,Front/Rear	kg	3930/560	4170/680	4450/700	4850/750
Battery						
6.01	Battery Voltage/rated capacity(K ₂)	V/Ah	48/404	48/404	48/404	48/404
6.02	battery weight	kg	265	265	270	270
Motor & Controller						
7.01	Drive Motor – 60 Min. Rating	kW	5.4x2	5.4x2	5.4x2	5.4x2
7.02	Pump Motor – S3 15% Rating	kW	11	11	11	11
7.03	Drive Motor Control Method		MOSFET/AC	MOSFET/AC	MOSFET/AC	MOSFET/AC
7.04	Pump Motor Control Method		MOSFET/AC	MOSFET/AC	MOSFET/AC	MOSFET/AC
7.05	Service Brake/Parking Brake		Electric/Electric	Electric/Electric	Electric/Electric	Electric/Electric
7.06	Relief Pressure	Mpa	17.5	21	17.5	17.5

NOTE:(1)Detailed information about battery,please contact our salesman or engineer.(2)For configuration number, 2: ZAPI Controller.

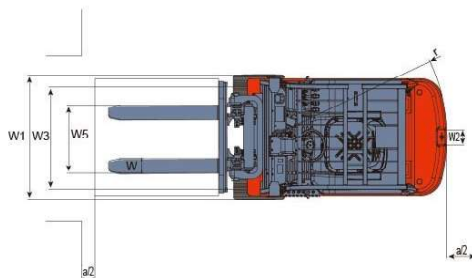
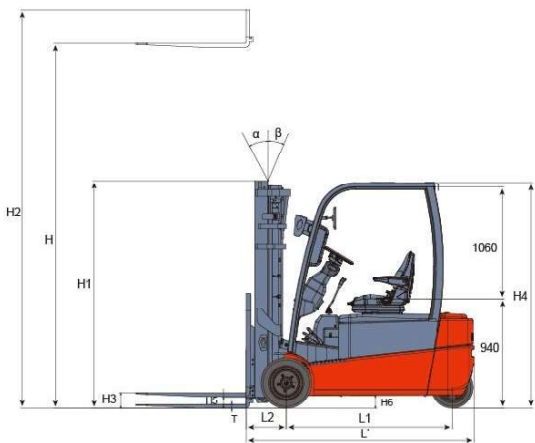

Ast: Right angle stacking aisle width
a: Clearance, 200mm

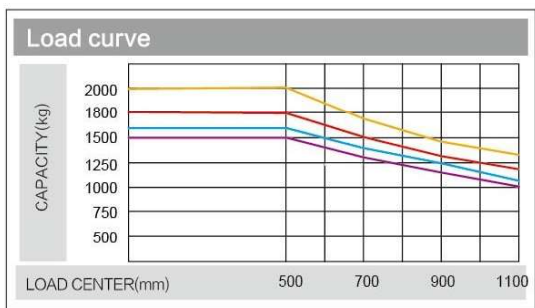

CPD15 CPD16 CPD18 CPD20

Note: The vertical axis stands for load capacity and the horizontal axis stands for load center which is calculated from the front surface of the forks to the gravity of the standard load. The standard load means a cubic with 1000mm edge length. When mast is tilted forward, using non-standard forks or loading large goods, the load capacity will be reduced. The load capacity of standard mast at different load center can be known from this load chart.

LITHIUM BATTERY

MODEL	Configuration	Voltage(V)	Capacity(Ah)	Supplier
CPD15/16SQ-GB2LI	Standard	48	404	ENEROC
CPD18/20SQ-GB2LI	Standard	48	404	ENEROC
	Optional	48	542	ENEROC

RENEWABLE ENERGY TECHNOLOGIES

With the use of the excellent load-sensing steering system and AC controlling renewable energy technologies, the forklift is more energy-saving and the working hour of the battery is extended by 15%.



15%

WIDE VIEW MAST

Mast model	Max. Lift height (mm)	Capacity at 500mm/load center				Height with mast lowered (mm)	Tilting Angle (α/β)(°)	service weight(Kg)			
		1.5t	1.6t	1.8t	2.0t			1.5t	1.6t	1.8t	2.0t
M200	2000	1500	1600	1800	2000	1525	5-7	2836	3111	3111	3461
M250	2500	1500	1600	1800	2000	1775	5-7	2862	3137	3137	3487
M300	3000	1500	1600	1800	2000	2025	5-7	2889	3164	3164	3514
M330	3300	1500	1600	1800	2000	2175	5-7	2905	3180	3180	3530
M350	3500	1500	1600	1750	2000	2275	5-7	2915	3190	3190	3540
M370	3700	1500	1600	1750	2000	2375	5-7	2929	3304	3204	3554
M400	4000	1500	1600	1750	1950	2575	3-5	2973	3248	3248	3598
M425	4250	1500	1600	1750	1900	2700	3-5	2986	3261	3261	3611
M450	4500	1400	1500	1700	1850	2825	3-5	2999	3274	3274	3624
M500	5000	1300	1400	1600	1700	3075	3-3	3025	3300	3300	3650
M550	5500	1100	1200	1400	1400	3375	3-3	3106	3381	3381	3731
M600	6000	800	900	1000	1100	3625	3-3	3135	3410	3410	3760

WIDE VIEW FULL FREE 2-STAGE MAST

Mast model	Max. Lift height (mm)	Capacity at 500mm/load center				Height with mast lowered (mm)	Free lift (with Backrest)	Tilting Angle (α/β)(°)	service weight(Kg)			
		1.5t	1.6t	1.8t	2.0t				1.5t	1.6t	1.8t	2.0t
ZM200	2000	1500	1600	1800	2000	1525	510	5-7	2867	3142	3142	3492
ZM250	2500	1500	1600	1800	2000	1775	760	5-7	2895	3170	3170	3520
ZM300	3000	1500	1600	1800	2000	2025	1010	5-7	2924	3199	3199	3549
ZM330	3300	1500	1600	1800	2000	2175	1160	5-7	2941	3216	3216	3566
ZM350	3500	1500	1600	1750	2000	2275	1260	5-7	2952	3227	3227	3577
ZM370	3700	1500	1600	1750	2000	2375	1360	5-7	2967	3242	3242	3592
ZM400	4000	1500	1600	1750	1950	2575	1560	3-5	3011	3286	3286	3636

NOTE: 1.5-2T:free lifted height 394mm increased without backrest.

WIDE VIEW FULL FREE 3-STAGE MAST

Mast model	Max. Lift height (mm)	Capacity at 500mm/load center				Height with mast lowered (mm)	Free lift (with Backrest)	Tilting Angle (α/β)(°)	service weight(Kg)			
		1.5t	1.6t	1.8t	2.0t				1.5t	1.6t	1.8t	2.0t
ZSM360	3600	1500	1600	1750	2000	1790	775	3-5	3038	3313	3313	3663
ZSM400	4000	1500	1600	1750	2000	1925	910	3-5	3065	3340	3340	3690
ZSM435	4350	1400	1500	1700	1900	2040	1025	3-5	3089	3364	3364	3714
ZSM450	4500	1400	1500	1700	1850	2090	1075	3-5	3099	3374	3374	3724
ZSM470	4700	1350	1450	1650	1750	2160	1145	3-5	3113	3388	3388	3738
ZSM480	4800	1350	1450	1650	1750	2190	1175	3-5	3119	3394	3394	3744
ZSM500	5000	1200	1300	1600	1700	2290	1275	3-3	3139	3414	3414	3764
ZSM540	5400	1050	1150	1250	1400	2425	1410	3-3	3167	3442	3442	3792
ZSM600	6000	800	900	1000	1100	2640	1625	3-3	3210	3485	3485	3835
ZSM650	6500	700	800	900	1000	2830	1815	3-3	3248	3523	3523	3873

NOTE: 1.5-2T:free lifted height 364mm increased without backrest.
1.5-2T:free lifted height 364mm increased without backrest when assemble with pulley block.