

SPECIFICATIONS

2012

		2012
DIMENSIONS	A. Overall Operating Height – Fully Raised	3167 mm
	B. Height to Hinge Pin – Fully Raised	2438 mm
	C. Overall Height to Top of ROPS	1897 mm
	D. Overall Length with Bucket	2576 mm w/ 914 mm Bucket
	E. Dump Angle at Full Height	46°
	F. Dump Height	1836 mm
	G. Dump Reach at Full Height	376 mm
	J. Rollback at Ground	23°
	M. Rollback Angle at Full Height	100°
	O. Seat to Ground Height	879 mm
	P. Wheelbase	775 mm
	Q. Overall Width - Less Bucket ^A	909 mm
	R. Bucket Width	914 mm
	S. Ground Clearance to Chassis	150 mm
	V. Overall Length - Less Bucket	1905 mm
	W. Departure Angle	30°
	X. Clearance Circle – Front w/ Bucket	1473 mm
	Y. Clearance Circle – Front w/o Bucket	833 mm
	Z. Clearance Circle – Rear	1097 mm
	Standard Specification Tire Size	
ENGINE	Make	Yanmar
	Model	3TNV82A-BPMSR Stage 3A
	Gross Power @ rpm	18.1 kW @2800
	Net Power (kW) @ rpm	17.8 kW @ 2400
	Maximum Torque @ rpm	86 Nm @ 1200
	Displacement	1.3 L
HYDRAULIC SYSTEM	Auxiliary Hydraulics – Standard	38.2 L/min
	High-Flow Auxiliary Hydraulics – Option	N/A
	Reservoir Capacity	27.3 L
ELECTRICAL SYSTEM	Battery	650 CCA
	Starter	1.7 kW
	Alternator	40-amp
CAPACITIES / WEIGHTS	Rated Operating Capacity ^B	386 kg
	Rated Op. Capacity with Opt. Counterweight ^B	N/A
	Fuel Tank	29 L
	Travel Speed – Maximum	8.9 km/hr
	Travel Speed w/ Two-Speed Option - Maximum	N/A
	Operating Weight ^C – Approximate	1352 kg
SOUND / VIBRATION*	Noise Level / Environmental Level	101 dB
	Operator Ear	85 dB
	Whole-Body Vibration ¹	≤ 0.81 m/s ²
	Hand-Arm Vibration	≤ 0.93 m/s ²

* Standard seat option and dual hand controls

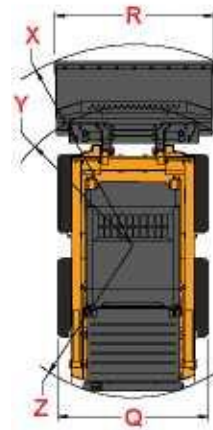
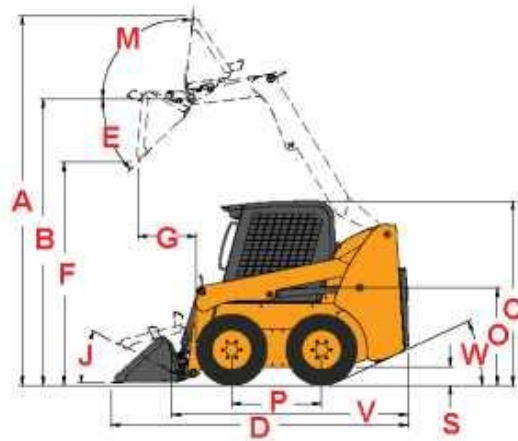

MUSTANG

